

PL 10" Woofer



Type Number: PL26WR09-04

Features:

The PL series is designed for the discerning audiophile customer. To meet the needs of this audience, several new technologies were developed with the goal of lowering distortion and damping in the speaker. The coated paper cone reduces vibration and standing waves, and the vented motor system minimizes power compression. The combined result is a very open and dynamic sound.

Driver Highlights: Magnesium Chassis, NRSC cone, NR rubber surround



Specs:

Electrical Data

Nominal impedance	Zn	4	ohm
Minimum impedance	Zmin	--	ohm
Maximum impedance	Zo	32	ohm
DC resistance	Re	3.2	ohm
Voice coil inductance	Le	1.7	mH

T-S Parameters

Resonance Frequency	fs	26	Hz
Mechanical Q factor	Qms	4.49	
Electrical Q factor	Qes	0.38	
Total Q factor	Qts	0.35	
Force factor	Bl	8.7	Tm
Mechanical resistance	Rms	1.94	Kg/s
Moving mass	Mms	55	g
Suspension compliance	Cms	--	mm/N
Effective cone diameter	D	--	cm
Effective piston area	Sd	337	cm ²
Equivalent volume	Vas	110	ltrs
Sensitivity (2.83V/1m)		89	dB
Ratio BL/√(Re)		--	
Ratio fs/Qts	F	--	

Power handling

100h RMS noise test (IEC)	--	W
Long-term Max Power (IEC 18.3)	350	W
Max linear SPL (rms) @ power	--	dB/W
Short Term Max power (IEC 18.2)	600	W

Voice Coil and Magnet Parameters

Voice coil diameter	50	mm
Voice coil height	16	mm
Voice coil layers	--	
Height of the gap	8	mm
Linear excursion +/-	--	mm
Max mech. excursion +/-	--	mm
Flux density of gap	--	mWb
Total useful flux	--	mWb
Diameter of magnet	--	mm
Height of magnet	--	mm
Weight of magnet	1.05	Kg

Notes:
IEC specs refer to IEC 60268-5 third edition.
All Tymphany products are RoHS compliant.

Frequency: PL26WR09-04

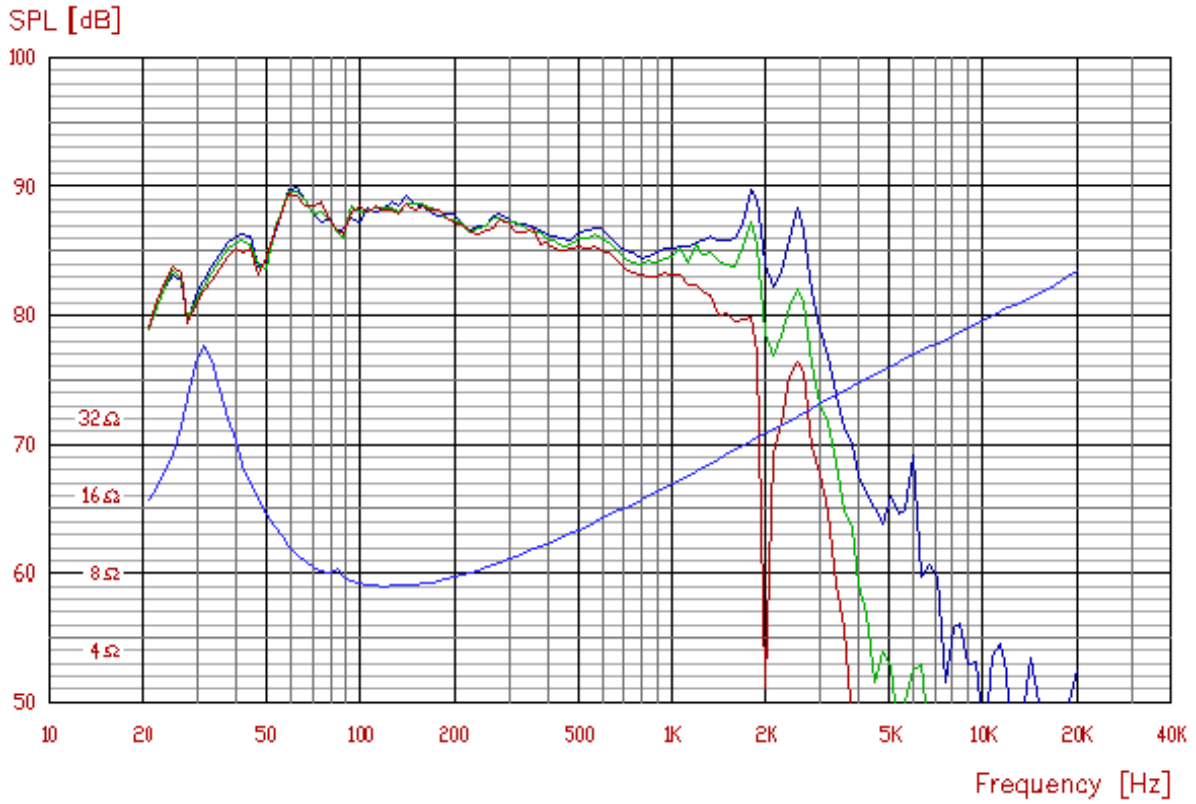

Mechanical Dimensions: PL26WR09-04

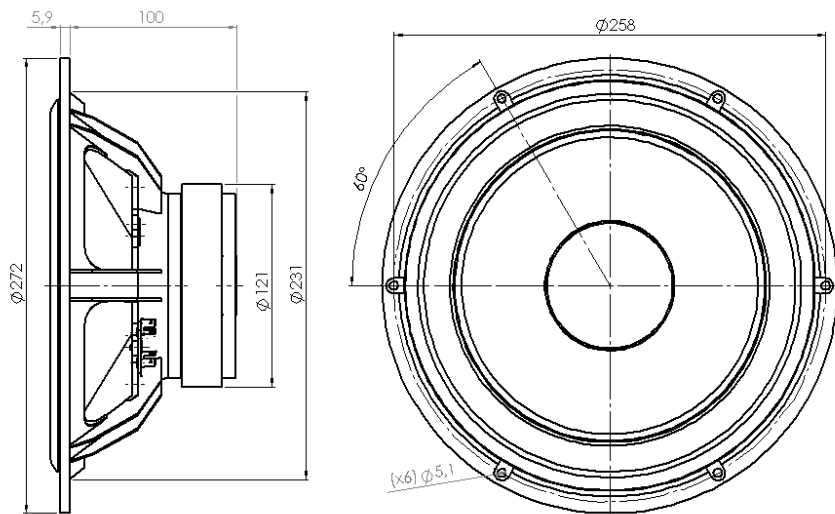

PL26WR09-04
PL26WR09-08